

LÉGENDE

- Gaine de frein
- Gaine de vitesse
- Gaine de tige de selle
- Gaine à l'extérieur du cadre
- - - Gaine à l'intérieur du cadre

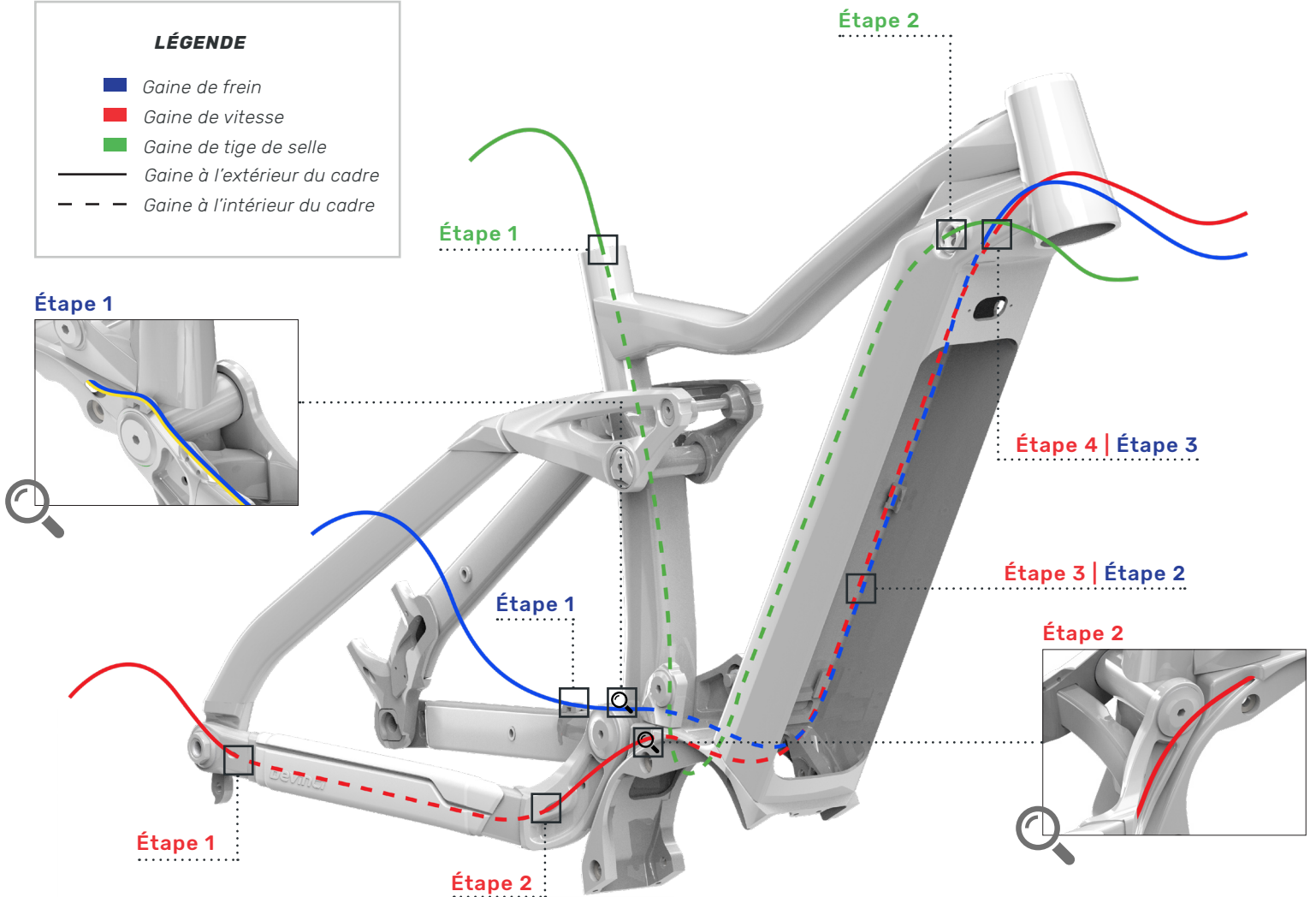

GAINES DE FREIN

Étape 1 | Fixez la gaine de frein aux supports de la base. Rentrez la gaine de frein dans la cavité située sur le support à moteur.

Étape 2 | Rentrez la gaine de frein à l'intérieur de la diagonale et attachez celle-ci à la butée gauche de la diagonale.

Étape 3 | Ressortez la gaine de frein par la cavité supérieure de la butée avant gauche située en haut de la diagonale.

GAINES DE VITESSE

Étape 1 | Passez la gaine dans l'ouverture avant de la base afin de la faire ressortir à l'arrière.

Étape 2 | Passez la gaine de vitesse dans la cavité située sur le support du moteur.

Étape 3 | Rentrez la gaine de vitesse à l'intérieur de la diagonale et attachez celle-ci à la butée gauche à l'intérieur de la diagonale.

Étape 4 | Ressortez la gaine de vitesse par la butée inférieure gauche située en haut de la diagonale.

GAINES DE TIGE DE SELLE (MÉCANIQUE)

Étape 1 | Passez la gaine de tige de selle dans le tube de selle et sortez-la par le support à batterie.







Étape 2 | Rentrez la gaine de tige de selle à l'intérieur de la diagonale et attachez celle-ci à la butée droite à l'intérieur de la diagonale.

Étape 3 | Ressortez la gaine de tige de selle par la butée droite située en haut de la diagonale.

GAINES DE TIGE DE SELLE (HYDRAULIQUE)

** Effectuez les mêmes étapes que pour la gaine de tige de selle mécanique, mais commencez par l'étape 2 et finissez par l'étape 1.

LÉGENDE

-  Interrupteur
-  Câble DI-2
-  Port de recharge
-  Capteur de vitesse
-  Gaine à l'extérieur du cadre
-  Gaine à l'intérieur du cadre

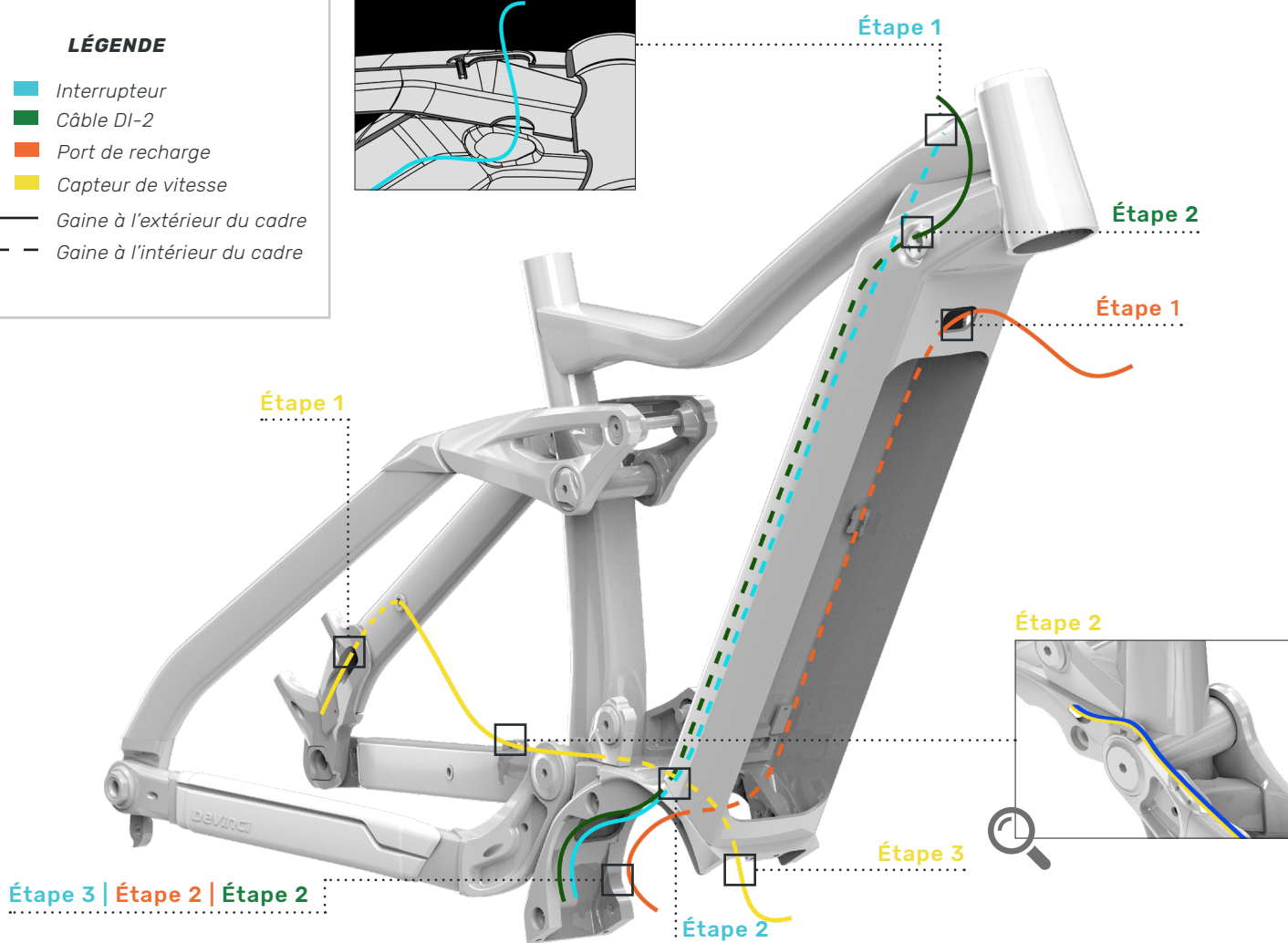
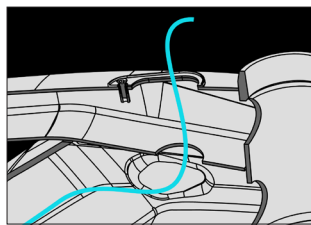

INTERRUPTEUR

Étape 1 | Positionnez l'espaceur et entrez le câble de l'interrupteur à l'endroit prévu à cet effet sur le tube du dessus jusqu'à ce que l'interrupteur soit en place.

Étape 2 | Sortez le câble de l'interrupteur à l'extrémité du compartiment à batterie et fixez à la butée droite du compartiment.

Étape 3 | Connectez le câble au moteur et fixez l'interrupteur.

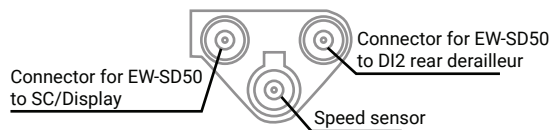

CAPTEUR DE VITESSE

Étape 1 | Passez le câble à l'intérieur du hauban. Ressortez le câble par la cavité située à l'intérieur du hauban.

Étape 2 | Fixer le câble du capteur aux butées de la base et faire entrer dans la même cavité que la gaine de frein située au niveau du support à moteur.

Étape 3 | Branchez le câble sur le moteur.

PORT DE RECHARGE

Étape 1 | Rentrez l'extrémité du câble de recharge par la cavité ovale située sous le devant du tube inférieur. Attachez le câble à la butée intérieure gauche.

Étape 2 | Branchez dans le support à batterie.

CÂBLE DI-2

Étape 1 | Passez le câble du conducteur par la cavité supérieure de la butée avant droite située en haut de la diagonale.

Étape 2 | Sortez le câble par l'ouverture du moteur.

LÉGENDE

- Gaine de frein
- Gaine de vitesse
- Câble DI-2
- Port de recharge
- Interrupteur
- Gaine de tige de selle

Fixez les gaines et les câbles aux butées à l'aide d'attaches à l'intérieur du cadre.

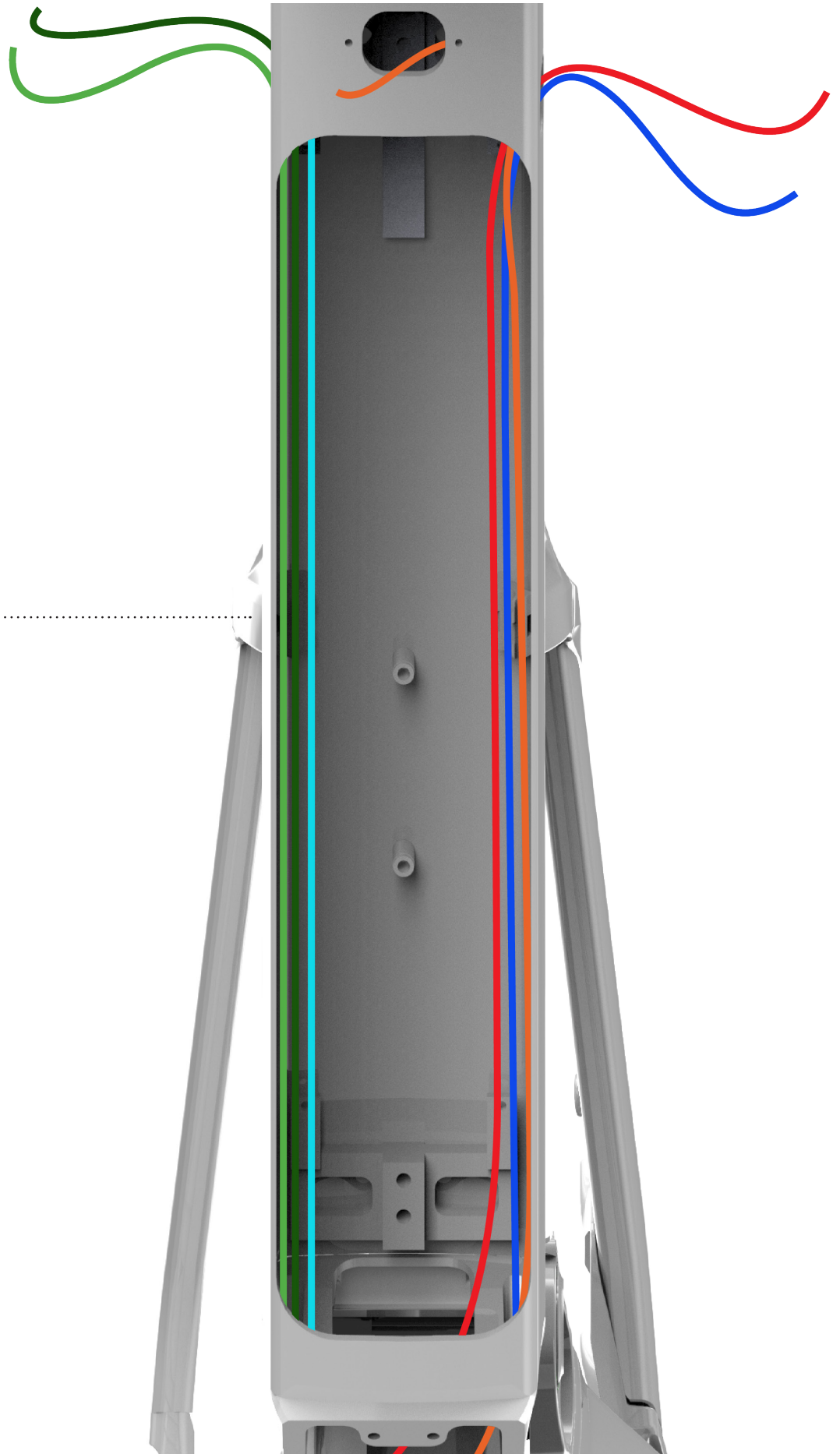

DeVinci

TECHNICAL MANUAL
E-MTB AC-DC& EP



PLEASE READ BEFORE USING YOUR BIKE

Even if you have already piloted a bike for years, it is important to be aware of the information contained in the "User Manual" and the Specific Manual (Power-Assisted Bike) PAB carefully before riding your new "AC, DC or EP".

- These documents contain important information.
- Understand the use, layout and maintenance of each electrical component of your new PAB.

Your safety and those of other users is paramount.

- Never ride the bike without its battery; the battery must be on the bike when you head out, otherwise there will be no lights on the bike.
- Never ride the bike without a saddle; failure to comply with this rule could lead to accidents.
- Inspect your bike to make sure there are no loose screws or components, or damages. In the event of a defect, visit your authorized Devinci retailer for repair.
- A PAB is faster than a normal bike; risks of accident with other users on the road may occur.
- Ride under the conditions mentioned below: (List the type of appropriate conditions for the bike).
- For PAB's that have a rear rack: the limit is 20 kg.

The electrical system requires careful handling:

- Do not clean the bike with a high-pressure jet. The system is sensitive to moisture. High-pressure water may seep into the connectors or other parts of the electrical system.
- Handle the battery carefully and pay attention to electric shocks. Failure to comply with this instruction could lead to abnormal heating or severe damage. In very rare cases, the consequences of an electrical shock could lead to a fire. In case of doubt, have the battery inspected by an authorized Devinci retailer

Perform maintenance of the battery as mentioned in the Technical Manual:

Note: Failure to follow the instructions below may damage the battery and require you to purchase a new battery kit.

- Charge the battery only with the Shimano charger.
- When the battery is not used for a long time, recharge it to 100% (from 4 to 5 LEDs on the charge indicator).
- Check the battery charge status regularly when not in use, recharge it to 100% if the load is less than 20% (1 indicator light on the charge gauge). Check the load at least every month and have it fully charged every 6 months.
- It is not recommended to keep the battery connected to the charger for a long period.
- If the battery remains uncharged for a long time, it can lose a significant part of its effectiveness.
- Store the battery in a well-ventilated and dry place. Pay attention to moisture.
- In case of poor conditions, remove the battery from the bike and store it in a dry place until next use.
- The battery can be stored at temperatures between -10°C and 40°C. For long service life, store it at a temperature close to 20°C.
- Monitor the storage temperature and try to avoid discrepancies. For example, do not leave the battery in your car during summer or leave the battery outdoors during a storm in winter.
- It is recommended to store a battery which is not connected to the bike.

Follow the transport instructions for your PAB:

- Remove the battery, the control screen and (if necessary) the baskets, arrange them elsewhere in a vehicle during transport.
- Comply with local laws regarding transportation of the PAB.
- A PAB is heavier than a normal bike, so you must be careful when transporting it. Check that the maximum load of the rack, roof or bike rack used is respected. Refer to the support manual used.
- The Li-Ion battery of your PAB, due to its size, is considered a "Class 9 dangerous goods" during transport. Applicable regulations could limit transport of a separate Li-Ion battery (when the battery is not on the bike) in some places. This regulation applies to several airlines and a number of road transport companies. On the other hand, if you are planning to move around with a full PAB (when the battery is on the bike), regulations are less strict. In case you use these transport methods, check the regulations that apply to your PAB with your transport company, before booking.

Visit your authorized Devinci retailer for regular maintenance of your new PAB:

- Only your retailer has the know-how and the proper equipment to maintain your PAB.
- If you have any questions about your PAB, please ask for assistance from your retailer!



ABOUT OUR MANUALS

Our user manuals meet EN 15194, 14766 standards.

Like many sports, cycling involves risk of injury and accidents, so you must be fully aware of these risks. Neither the manufacturer, the retailer, nor the person who sold you the bike, nor the people who maintain the trails are responsible for these risks. As you are solely responsible, it is, therefore, essential that you read and fully understand all the parts contained in this manual and the user manual.

To enjoy maximum safety and enjoyment right from the get go, it is important that you are familiar with your new bike, its handling and its possibilities. It is your duty to maintain your bike well and reduce the risk of injury. Biking can be a dangerous activity, even under the best conditions. There are risks associated with using a bicycle that cannot be predicted or avoided. These are the sole responsibility of the cyclist.



YOUR AUTHORIZED DEVINCI DEALER

Your authorized Devinci retailer is at your service to guide your choices of bike and accessories which are best suited to the style of biking you wish to perform. This will help you maintain your equipment in good condition so that you can take full advantage of your investment. The staff at your authorized Devinci retailer have the training, experience and tools to carry out the right repairs and provide you with reliable advice.

However, your authorized Devinci retailer cannot make decisions for you, and cannot be held responsible for your lack of knowledge, experience, qualification or common sense. However, it will take the necessary time to explain the operation of a component or to help you choose an accessory that meets your specific needs.

For further information, please see the **User Manual** available on the Devinci website and the **Shimano STEPS EP800 & E7000 series user manual** available on <http://si.shimano.com/>. You can ask your authorized Devinci retailer. He will take the time to answer any questions you may have and will advise you, with great pleasure.

To learn more about your bike's warranty, refer to the User Manual under the "Ride in Peace with the Devinci Warranty" tab.

AC-DC		
ITEMS	#SERVICE KIT	DESCRIPTION
1	KFC19040	Bearing kit AC/DC/EP
2	KFC19041-01	AC/DC/EP Shock bolt Black
3	KFC11051	Derailleur Hanger Split Pivot 12x142/148
4	KFC19011	Rear Axle Boost148*12mm/201mm
5	KFC00001	Battery Protector AC/DC/EP
6	KFC00004	Motor Protector AC/DC EP800
7	KFC19043	Chainstay Protector kit AC/DC/EP
8	KFC19044	Cable Guide kit AC/DC/EP
9	KFC00003	Satellite parts spacers AC/DC/EP
10	KFC19045-01	Pivot kit Shaft AC/DC/EP Black

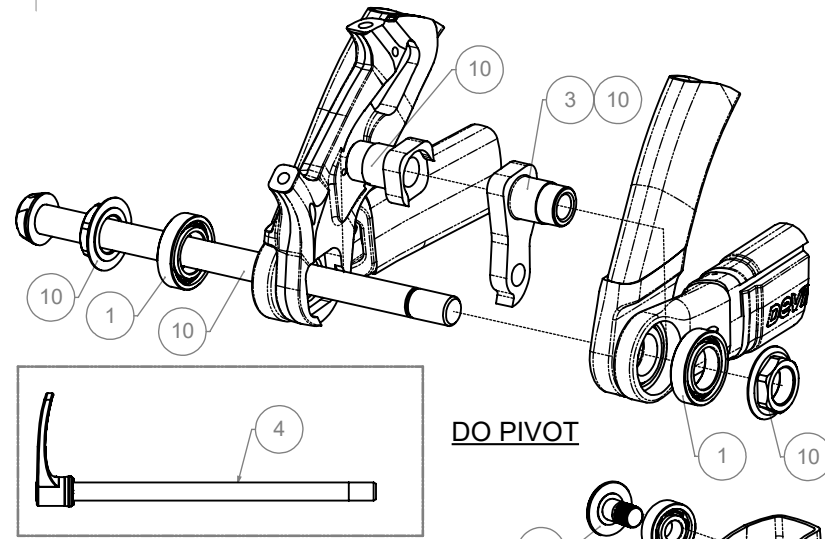

DO PIVOT

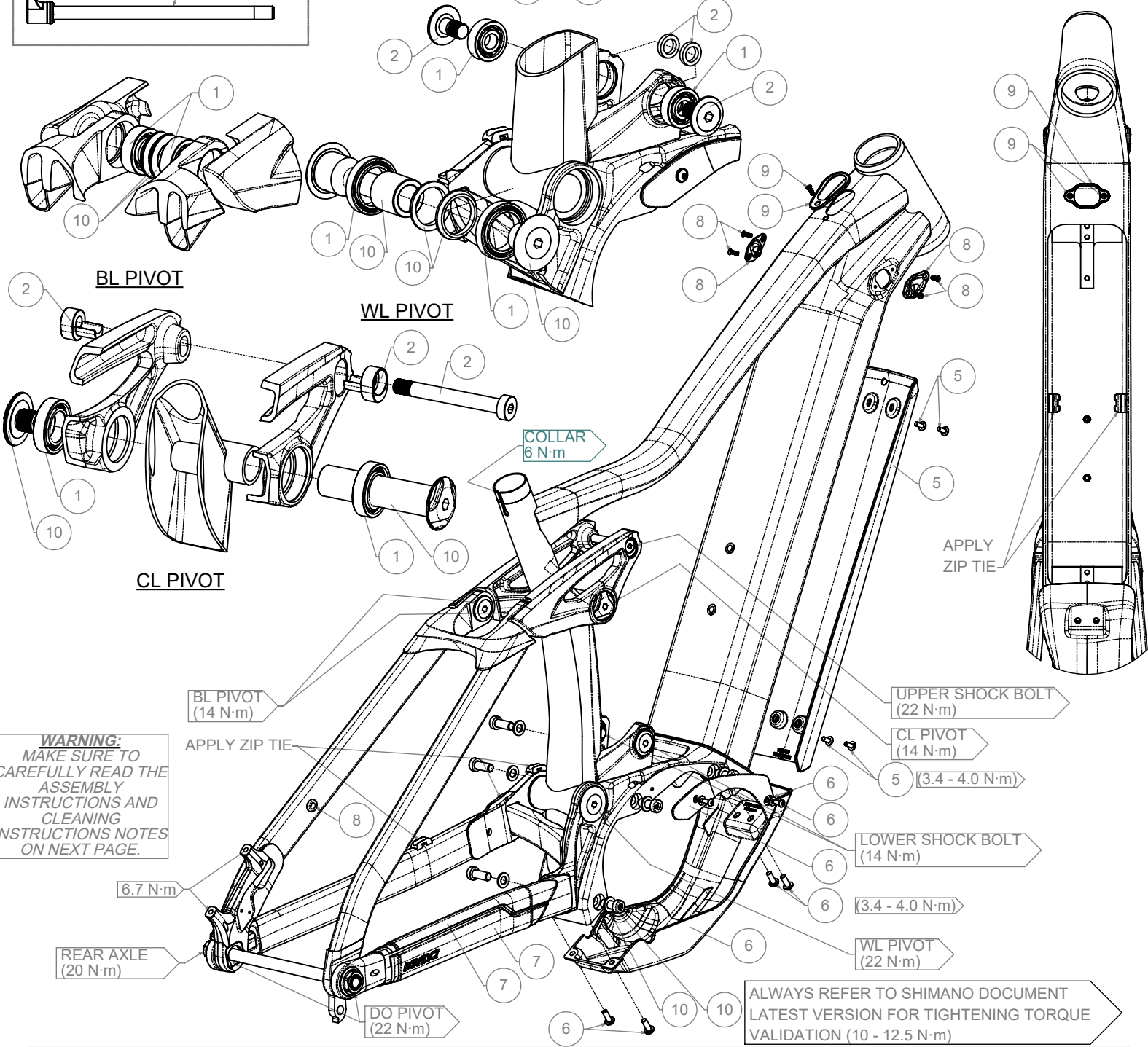

WARNING:
MAKE SURE TO CAREFULLY READ THE ASSEMBLY INSTRUCTIONS AND CLEANING INSTRUCTIONS NOTES ON NEXT PAGE.

ALWAYS REFER TO SHIMANO DOCUMENT LATEST VERSION FOR TIGHTENING TORQUE VALIDATION (10 - 12.5 N-m)

ASSEMBLY INSTRUCTIONS:

- 1- THOROUGHLY CLEAN THE INTERIOR OF EACH BEARING HOUSING TO REMOVE ANY DIRT OR OLD GREASE;
- 2- APPLY HIGH QUALITY WATERPROOF GREASE ON THE INSIDE FACE AND INSIDE DIAMETER OF ALL BEARING HOUSINGS BEFORE PRESS-FIT;
- 3- APPLY HIGH QUALITY WATERPROOF GREASE TO ALL PIVOT PARTS THAT CONTACT WITH THE INNER DIAMETER OF THE BEARINGS.
- 4- APPLY HIGH QUALITY WATERPROOF GREASE TO ALL NON-THREADED METAL-TO-METAL INTERFACES (EX.: PLANAR FACE OF THE PIVOT SPACER THAT CONTACTS THE LATERAL FACES OF THE FRONT TRIANGLE WL PIVOT). THESE INSTRUCTIONS ALSO APPLY TO THE SHOCK ASSEMBLY;
- 5- UNLESS OTHERWISE SPECIFIED, APPLY BLUE LOCTITE 242 ON ALL THREADS BEFORE ASSEMBLY TO THE SPECIFIED TORQUE VALUE;
- 6- TO PREVENT DAMAGE TO THE FRAME, THE SEATPOST MUST HAVE A MINIMUM INSERTION IN THE SEAT TUBE.

ALUMINIUM FRAME:

SMALL / MEDIUM / LARGE / X-LARGE - 100mm INSERTION

*ALWAYS VERIFY CONNECTOR CLEARANCE BEFORE FULLY INSERTING A DROPPER POST.

7- FRG ADJUSTABLE: THIS DESIGN ALLOWS RIDERS TO CHOOSE BETWEEN A LOW OR HIGH POSITION. WITH FRG ADJUSTABLE TECHNOLOGY, YOU CAN FINE-TUNE YOUR RIDE TO PERSONAL TASTES OR SPECIFIC TRAIL TYPES USING A FLIP-FLOP PIVOT MECHANISM THAT SLIGHTLY CHANGES THE BIKE'S GEOMETRY AS SHOWN BELOW.

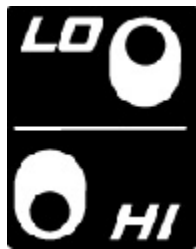

CLEANING INSTRUCTIONS:

IT IS A WELL KNOWN FACT THAT A CLEAN BIKE PERFORMS BETTER. DEVINCI RECOMMENDS WASHING YOUR BIKE REGULARLY USING A BRUSH AND SOAPY WATER. HOWEVER, DEVINCI DO NOT RECOMMEND THE USE OF A PRESSURE WASHER, SINCE THIS MAY SIGNIFICANTLY REDUCE THE SERVICE LIFE OF BALL BEARINGS. EVEN THOUGH OUR BALL BEARINGS ARE EQUIPPED WITH HIGH QUALITY DOUBLE-LIP SEALS, HIGH PRESSURE WATER CAN STILL PASS THESE SEALS AND REMOVE THE GREASE INSIDE THE BEARING. THIS MAY CAUSE PREMATURE CORROSION AND WEAR OF THE BALL BEARINGS.

DeVinci

TECHNICAL MANUAL
E-MTB AC-DC& EP



PLEASE READ BEFORE USING YOUR BIKE

Even if you have already piloted a bike for years, it is important to be aware of the information contained in the "User Manual" and the Specific Manual (Power-Assisted Bike) PAB carefully before riding your new "AC, DC or EP".

- These documents contain important information.
- Understand the use, layout and maintenance of each electrical component of your new PAB.

Your safety and those of other users is paramount.

- Never ride the bike without its battery; the battery must be on the bike when you head out, otherwise there will be no lights on the bike.
- Never ride the bike without a saddle; failure to comply with this rule could lead to accidents.
- Inspect your bike to make sure there are no loose screws or components, or damages. In the event of a defect, visit your authorized Devinci retailer for repair.
- A PAB is faster than a normal bike; risks of accident with other users on the road may occur.
- Ride under the conditions mentioned below: (List the type of appropriate conditions for the bike).
- For PAB's that have a rear rack: the limit is 20 kg.

The electrical system requires careful handling:

- Do not clean the bike with a high-pressure jet. The system is sensitive to moisture. High-pressure water may seep into the connectors or other parts of the electrical system.
- Handle the battery carefully and pay attention to electric shocks. Failure to comply with this instruction could lead to abnormal heating or severe damage. In very rare cases, the consequences of an electrical shock could lead to a fire. In case of doubt, have the battery inspected by an authorized Devinci retailer

Perform maintenance of the battery as mentioned in the Technical Manual:

Note: Failure to follow the instructions below may damage the battery and require you to purchase a new battery kit.

- Charge the battery only with the Shimano charger.
- When the battery is not used for a long time, recharge it to 100% (from 4 to 5 LEDs on the charge indicator).
- Check the battery charge status regularly when not in use, recharge it to 100% if the load is less than 20% (1 indicator light on the charge gauge). Check the load at least every month and have it fully charged every 6 months.
- It is not recommended to keep the battery connected to the charger for a long period.
- If the battery remains uncharged for a long time, it can lose a significant part of its effectiveness.
- Store the battery in a well-ventilated and dry place. Pay attention to moisture.
- In case of poor conditions, remove the battery from the bike and store it in a dry place until next use.
- The battery can be stored at temperatures between -10°C and 40°C. For long service life, store it at a temperature close to 20°C.
- Monitor the storage temperature and try to avoid discrepancies. For example, do not leave the battery in your car during summer or leave the battery outdoors during a storm in winter.
- It is recommended to store a battery which is not connected to the bike.

Follow the transport instructions for your PAB:

- Remove the battery, the control screen and (if necessary) the baskets, arrange them elsewhere in a vehicle during transport.
- Comply with local laws regarding transportation of the PAB.
- A PAB is heavier than a normal bike, so you must be careful when transporting it. Check that the maximum load of the rack, roof or bike rack used is respected. Refer to the support manual used.
- The Li-Ion battery of your PAB, due to its size, is considered a "Class 9 dangerous goods" during transport. Applicable regulations could limit transport of a separate Li-Ion battery (when the battery is not on the bike) in some places. This regulation applies to several airlines and a number of road transport companies. On the other hand, if you are planning to move around with a full PAB (when the battery is on the bike), regulations are less strict. In case you use these transport methods, check the regulations that apply to your PAB with your transport company, before booking.

Visit your authorized Devinci retailer for regular maintenance of your new PAB:

- Only your retailer has the know-how and the proper equipment to maintain your PAB.
- If you have any questions about your PAB, please ask for assistance from your retailer!



ABOUT OUR MANUALS

Our user manuals meet EN 15194, 14766 standards.

Like many sports, cycling involves risk of injury and accidents, so you must be fully aware of these risks. Neither the manufacturer, the retailer, nor the person who sold you the bike, nor the people who maintain the trails are responsible for these risks. As you are solely responsible, it is, therefore, essential that you read and fully understand all the parts contained in this manual and the user manual.

To enjoy maximum safety and enjoyment right from the get go, it is important that you are familiar with your new bike, its handling and its possibilities. It is your duty to maintain your bike well and reduce the risk of injury. Biking can be a dangerous activity, even under the best conditions. There are risks associated with using a bicycle that cannot be predicted or avoided. These are the sole responsibility of the cyclist.



YOUR AUTHORIZED DEVINCI DEALER

Your authorized Devinci retailer is at your service to guide your choices of bike and accessories which are best suited to the style of biking you wish to perform. This will help you maintain your equipment in good condition so that you can take full advantage of your investment. The staff at your authorized Devinci retailer have the training, experience and tools to carry out the right repairs and provide you with reliable advice.

However, your authorized Devinci retailer cannot make decisions for you, and cannot be held responsible for your lack of knowledge, experience, qualification or common sense. However, it will take the necessary time to explain the operation of a component or to help you choose an accessory that meets your specific needs.

For further information, please see the **User Manual** available on the Devinci website and the **Shimano STEPS EP800 & E7000 series user manual** available on <http://si.shimano.com/>. You can ask your authorized Devinci retailer. He will take the time to answer any questions you may have and will advise you, with great pleasure.

To learn more about your bike's warranty, refer to the User Manual under the "Ride in Peace with the Devinci Warranty" tab.

EP		
ITEMS	#SERVICE KIT	DESCRIPTION
1	KFC19040	Bearing kit AC/DC/EP
2	KFC19041-01	AC/DC/EP Shock bolt Black
3	KFC11051	Derailleur Hanger Split Pivot 12x142/148
4	KFC19011	Rear Axle Boost148*12mm/201mm
5	KFC00001	Battery Protector AC/DC/EP
6	KFC00201	Motor Protector EP E7000
7	KFC19043	Chainstay Protector kit AC/DC/EP
8	KFC19044	Cable Guide kit AC/DC/EP
9	KFC00003	Satellite parts spacers AC/DC/EP
10	KFC19045-01	Pivot kit Shaft AC/DC/EP Black

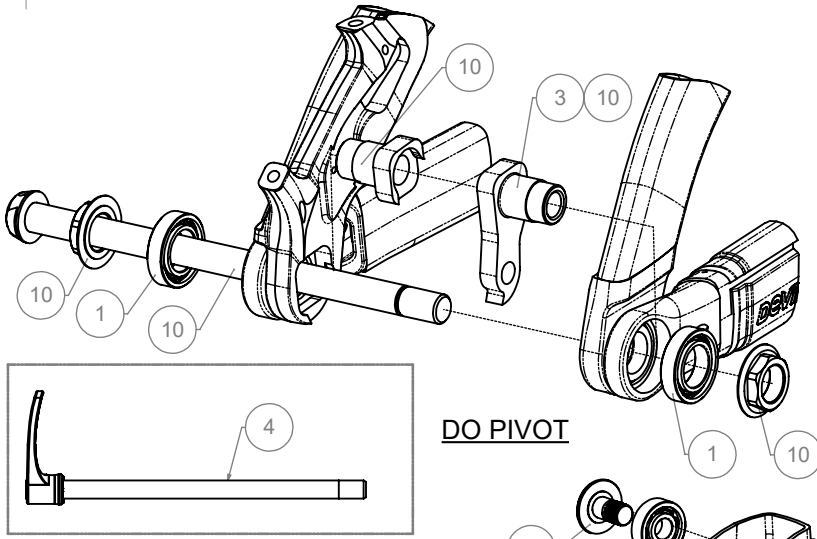

DO PIVOT

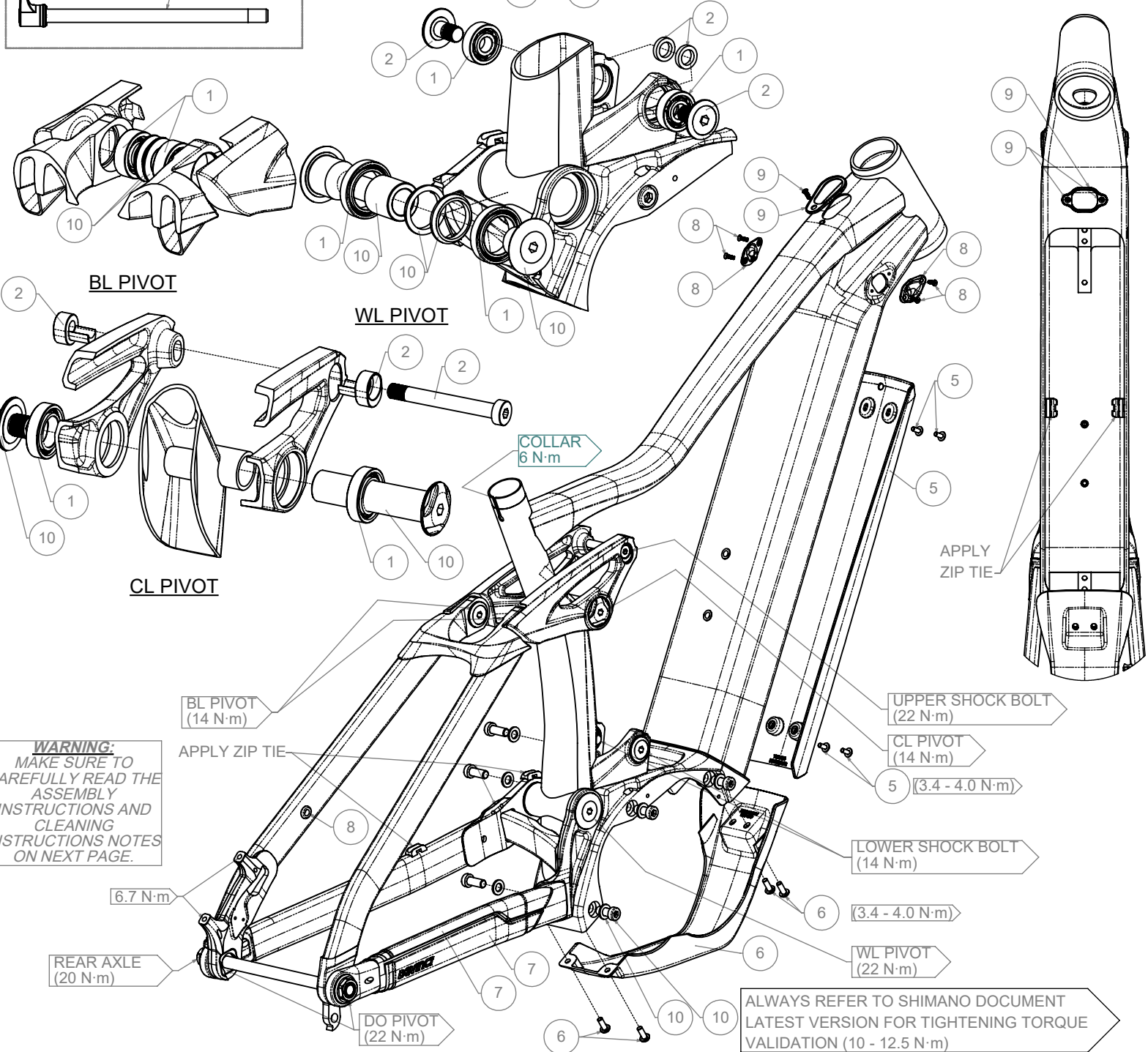

ASSEMBLY INSTRUCTIONS:

- 1- THOROUGHLY CLEAN THE INTERIOR OF EACH BEARING HOUSING TO REMOVE ANY DIRT OR OLD GREASE;
- 2- APPLY HIGH QUALITY WATERPROOF GREASE ON THE INSIDE FACE AND INSIDE DIAMETER OF ALL BEARING HOUSINGS BEFORE PRESS-FIT;
- 3- APPLY HIGH QUALITY WATERPROOF GREASE TO ALL PIVOT PARTS THAT CONTACT WITH THE INNER DIAMETER OF THE BEARINGS.
- 4- APPLY HIGH QUALITY WATERPROOF GREASE TO ALL NON-THREADED METAL-TO-METAL INTERFACES (EX.: PLANAR FACE OF THE PIVOT SPACER THAT CONTACTS THE LATERAL FACES OF THE FRONT TRIANGLE WL PIVOT). THESE INSTRUCTIONS ALSO APPLY TO THE SHOCK ASSEMBLY;
- 5- UNLESS OTHERWISE SPECIFIED, APPLY BLUE LOCTITE 242 ON ALL THREADS BEFORE ASSEMBLY TO THE SPECIFIED TORQUE VALUE;
- 6- TO PREVENT DAMAGE TO THE FRAME, THE SEATPOST MUST HAVE A MINIMUM INSERTION IN THE SEAT TUBE.

ALUMINIUM FRAME:

SMALL / MEDIUM / LARGE / X-LARGE - 100mm INSERTION

*ALWAYS VERIFY CONNECTOR CLEARANCE BEFORE FULLY INSERTING A DROPPER POST.

7- FRG ADJUSTABLE: THIS DESIGN ALLOWS RIDERS TO CHOOSE BETWEEN A LOW OR HIGH POSITION. WITH FRG ADJUSTABLE TECHNOLOGY, YOU CAN FINE-TUNE YOUR RIDE TO PERSONAL TASTES OR SPECIFIC TRAIL TYPES USING A FLIP-FLOP PIVOT MECHANISM THAT SLIGHTLY CHANGES THE BIKE'S GEOMETRY AS SHOWN BELOW.

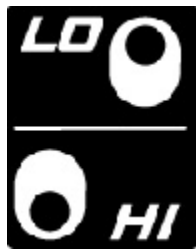

CLEANING INSTRUCTIONS:

IT IS A WELL KNOWN FACT THAT A CLEAN BIKE PERFORMS BETTER. DEVINCI RECOMMENDS WASHING YOUR BIKE REGULARLY USING A BRUSH AND SOAPY WATER. HOWEVER, DEVINCI DO NOT RECOMMEND THE USE OF A PRESSURE WASHER, SINCE THIS MAY SIGNIFICANTLY REDUCE THE SERVICE LIFE OF BALL BEARINGS. EVEN THOUGH OUR BALL BEARINGS ARE EQUIPPED WITH HIGH QUALITY DOUBLE-LIP SEALS, HIGH PRESSURE WATER CAN STILL PASS THESE SEALS AND REMOVE THE GREASE INSIDE THE BEARING. THIS MAY CAUSE PREMATURE CORROSION AND WEAR OF THE BALL BEARINGS.